

KM5PO

Using a TinyPFA for phase-frequency analysis Part 1

April 8, 2023

What is a TinyPFA?

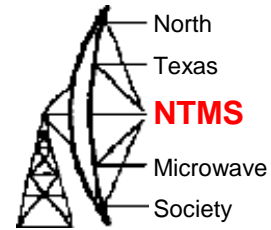

- [TinyPFA](#) is firmware from Erik Kaashoek for NanoVNA-H4 hardware for accurate measurement of oscillator and clock source stability.
- Firmware does not work with previous NanoVNA versions – must have the H4 hardware.

What is a TinyPFA?

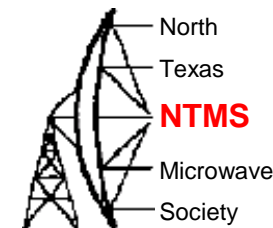

Very accurate phase and frequency measurement using the nanoVNA-H4 HW

« **on:** December 21, 2022, 02:29:54 pm »

For those that want to do very accurate phase and frequency measurements, but are not willing or capable to buy a PhaseStation or Timepod a new FW has been made available for the nanoVNA-H4 HW that converts it into a mix between a **DMTD** and PhaseStation.

Accuracy of phase measurements is better than $1e-12$ / (Tau in seconds) and the device support sending the phase measurements over USB to programs like TimeLab or writing to an internal SD card for later analysis.

During testing and comparing to other frequency and phase measurement devices, the tinyPFA outperformed conventional frequency counters and delivered phase measurements identical to a PhaseStation when used above the noise floor.

A wiki containing all the information for creating and using your own tinyPFA can be found here: <https://www.tinydevices.org/wiki/>

A support forum is available in case you have questions regarding the operation of the tinyPFA or want to share results

As the FW is fairly new you can expect some bugs.

The nanoVNA-H4 HW does not have to be modified so after use as a tinyPFA, it can always be converted back into a VNA.

DMTD ?

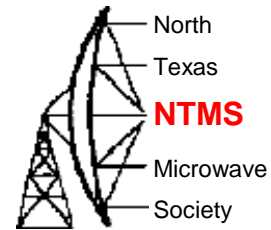

II. DIGITAL DUAL MIXER TIME DIFFERENCE

The goal of the DMTD consists in converting a phase shift from the high frequency domain into the low frequency domain, thus providing a very large time difference multiplication effect. When properly implemented, this time multiplication system allows the measurement of the short term frequency stability of two synchronous or quasi synchronous oscillators with an ultra-low background noise. It is also commonly used to measure the phase difference between two clock signals that have nearly equal frequencies, i.e., frequencies within a few hertz of one another. This technique has the benefit of cancelling most of the common clock phase noise [5].

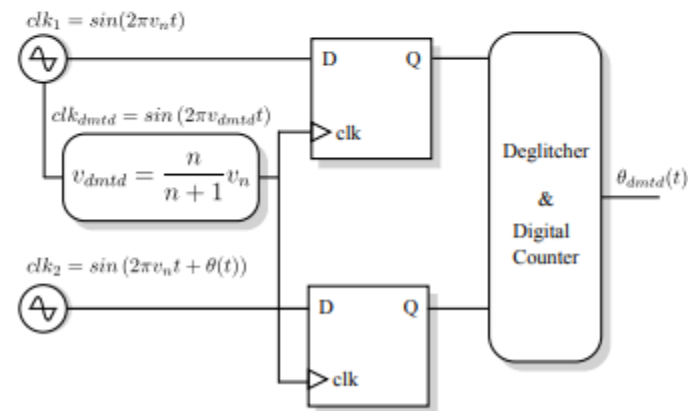
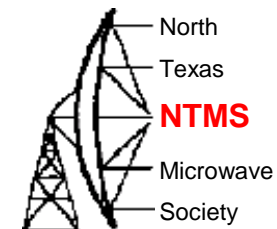

Fig. 2. Digital DMTD Schematic

OK, what for ?



- Two problems to solve
- My DB6NT 10 GHz transverter drifts
 - First thought to be OCXO/GPSDO RF levels
 - Now possibly a internal PLL locking issue
- Our 24 GHz Wavelab and 122 GHz equipment vary in frequency.
 - Need to understand how the 10 MHz reference frequency is influencing this

Basic use of the TinyPFA

- Set reference signal at correct level (-5 to -10 dBm)

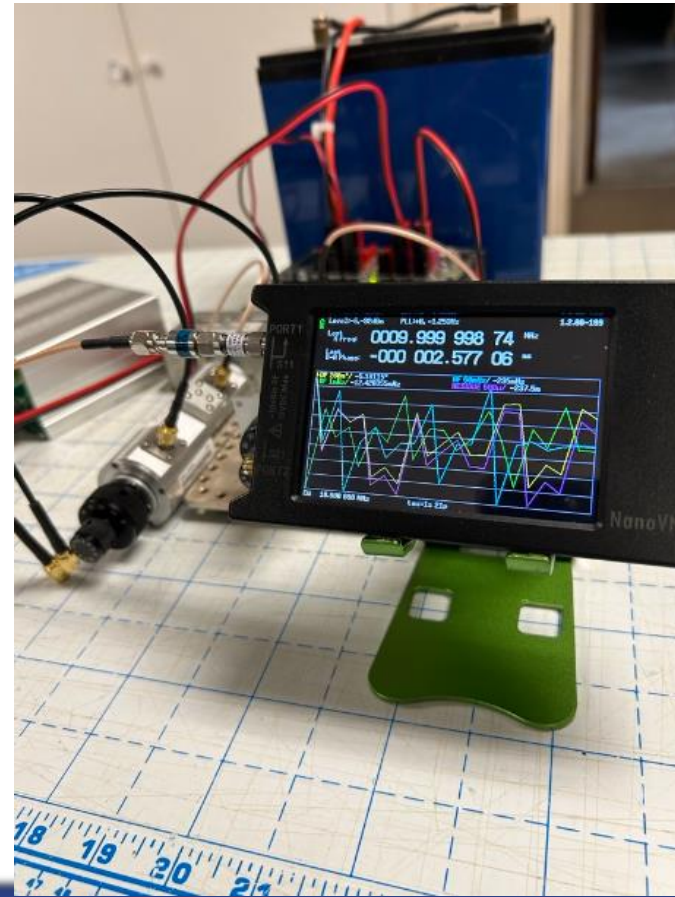
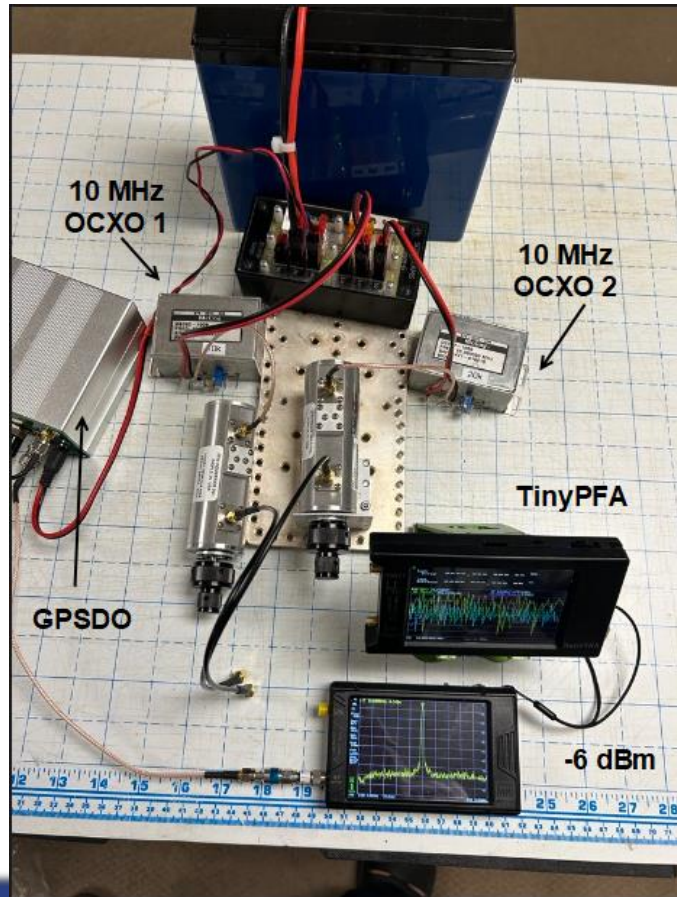

Basic use of the TinyPFA

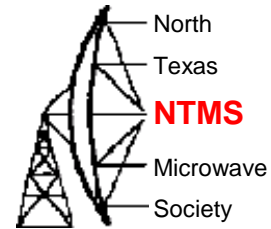

- Null port A signal (accept as the reference signal)

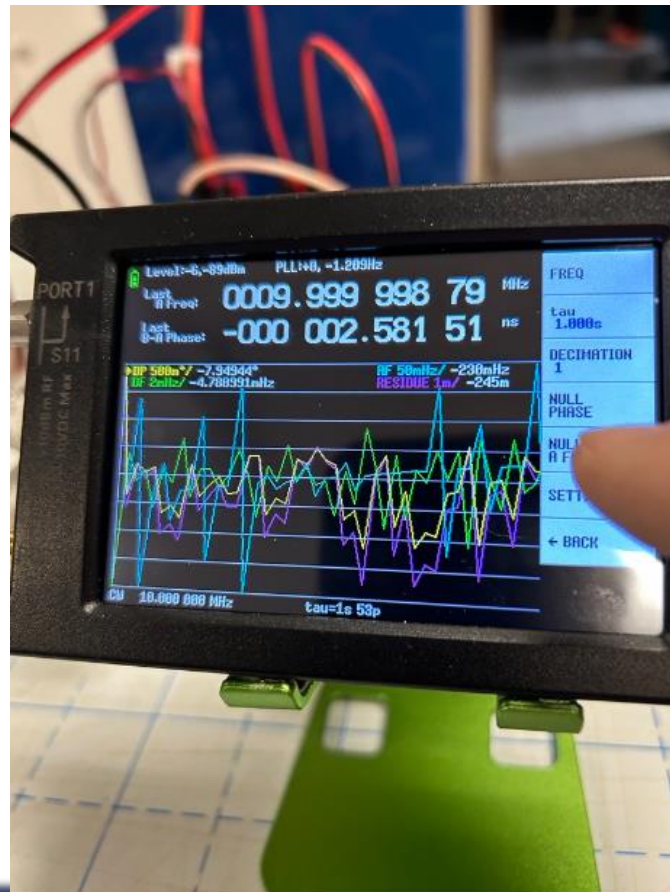

Basic use of the TinyPFA

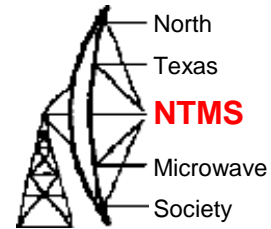

- Add second input on port B for measurement
- OCXO-1 has 11 millihertz diff, OCXO-2 has 20+ millihertz diff

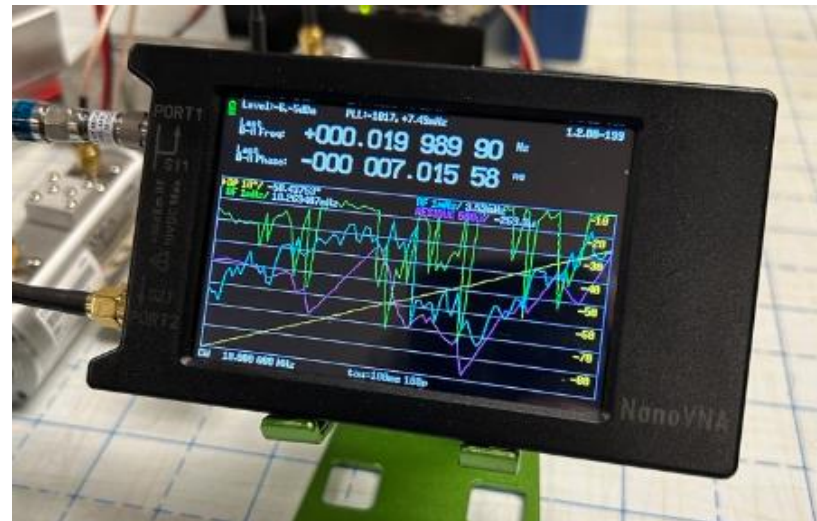
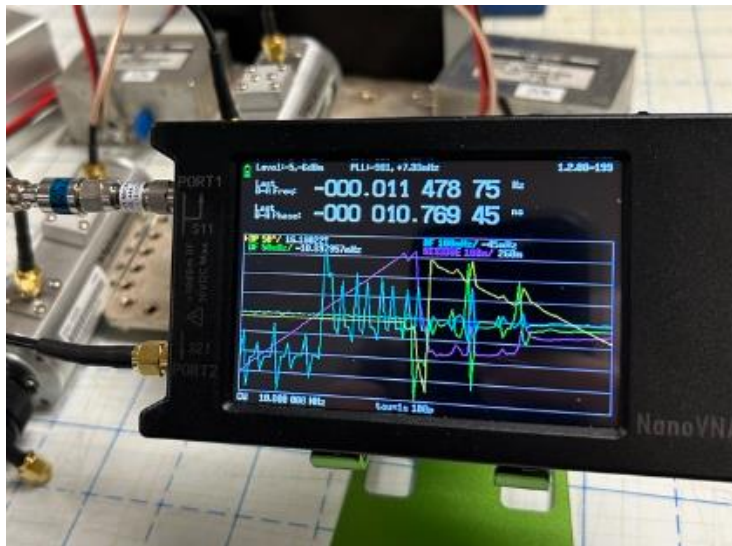

Basic use of the TinyPFA

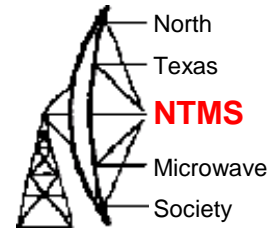

- Attach TimeLab to TinyPFA through USB port. Set configs.



TimeLab

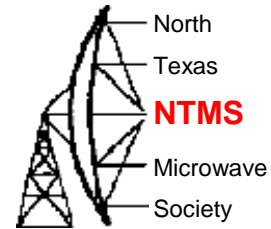

Frequency Difference
Averaging window: Per-pixel

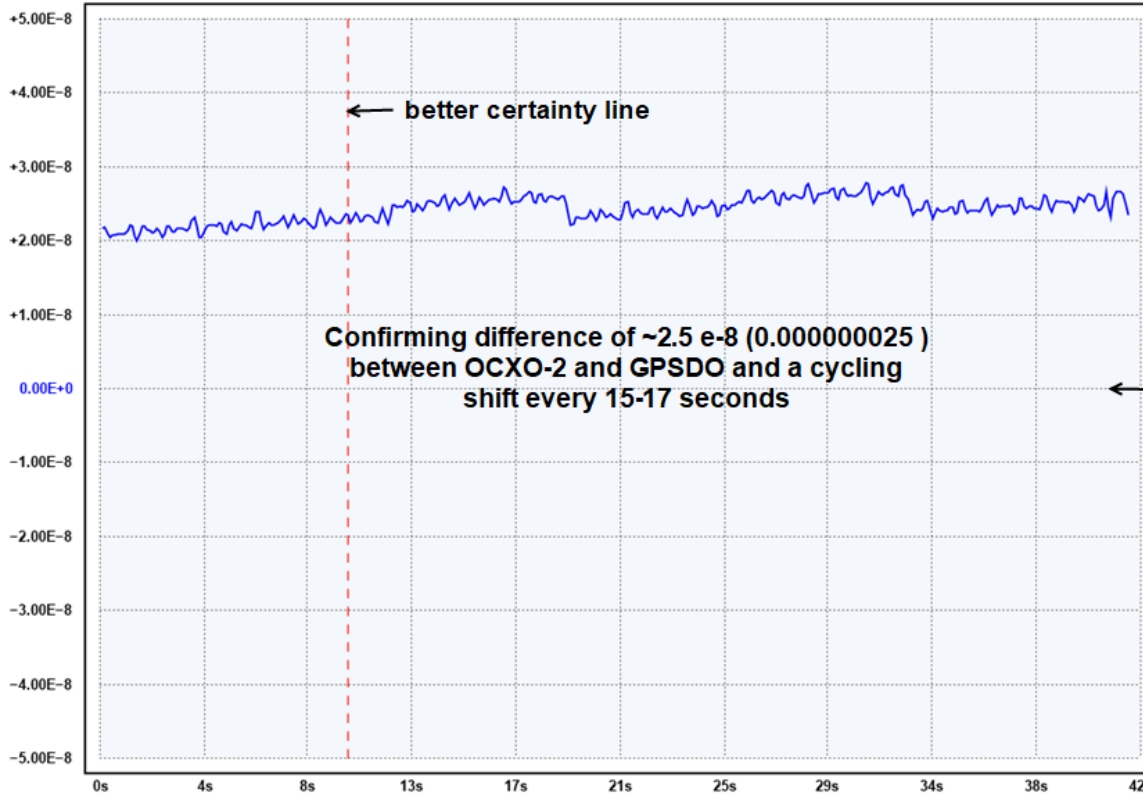

Origin	Drift (Hz/sec)	Drift (Hz/min)
+2.23E-8	+9.35E-4	+5.61E-2

Avg Time (s)	Freq (Hz) at 42s	Error
0.1	10 000 000.234 961 800	+2.35E-8
0.3	10 000 000.248 379 400	+2.48E-8
1	10 000 000.254 243 551	+2.54E-8
3	10 000 000.252 873 531	+2.53E-8
10	10 000 000.249 597 251	+2.50E-8
30	10 000 000.250 513 127	+2.51E-8

If OCXO matched ref GPSDO then the blue line would trace at 0.00

OCXO-2

Trace	Notes	Input Freq	Sample Interval	Freq at 10s	Duration	Elapsed	Acquired	Instrument
OCXO 20k to GPSDO (Unsaved)		10 MHz	0.100 s	10 000 000.234 Hz	1 h	6m 56s	416 pts	

Test 122 GHz

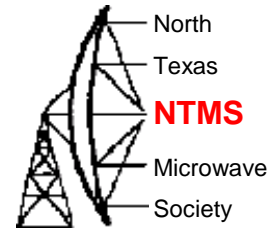

- 122 GHz “Reference transmitter” locked to GPS
- 122 GHz RX will alternate between OCXO-2 and GPSDO

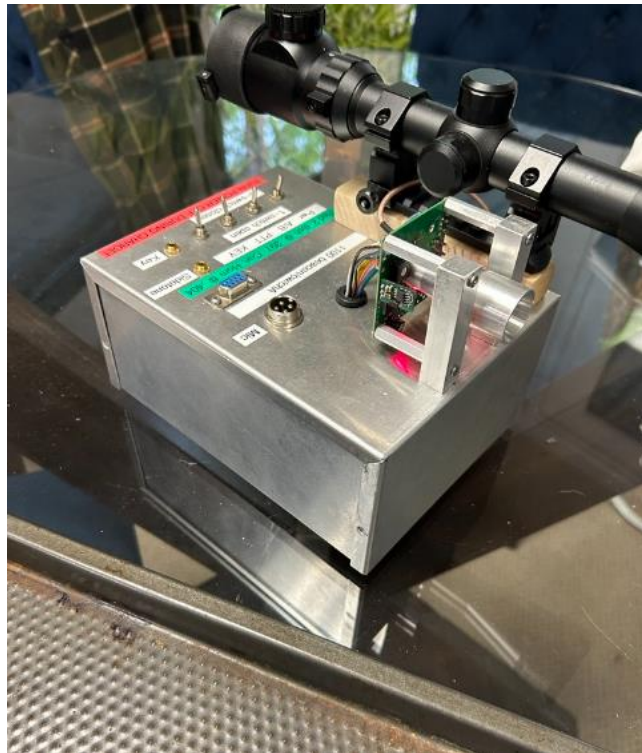

Test 122 GHz

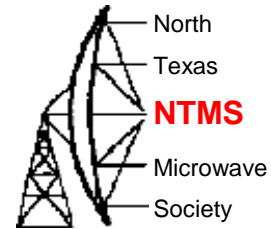

- RX on OCXO-2 receives at 122356.348.000
- RX on GPSDO receives at 122356.348.270 diff of 270 hz

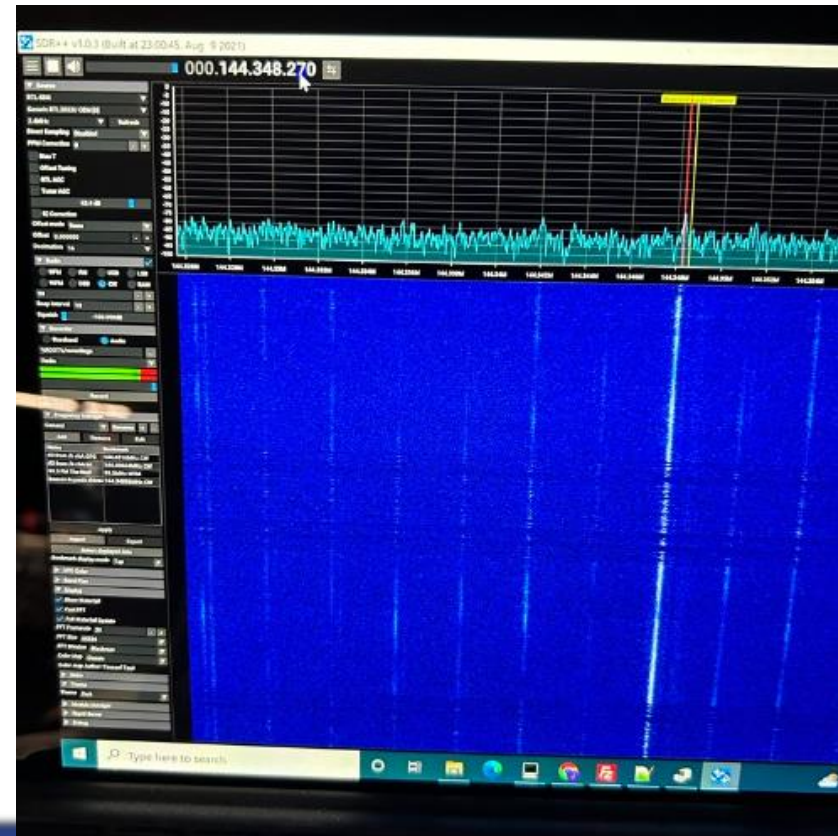
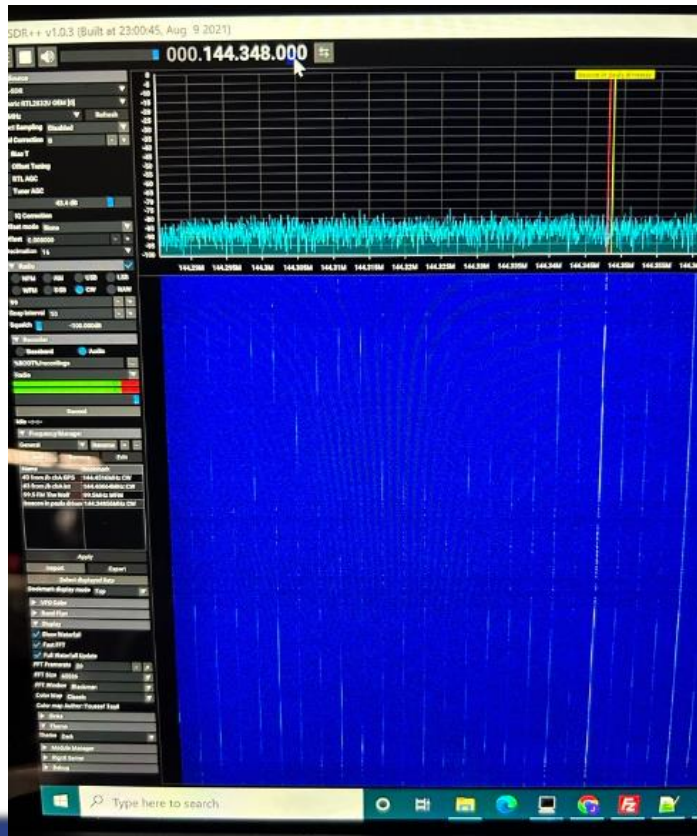

Test 122 GHz

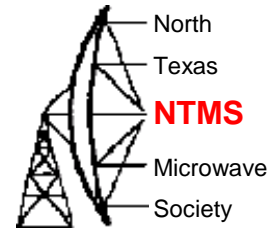

- Conclusion: 20+ millihertz diff at 10 MHz = 200+ hertz diff at 122 GHz
 - A factor of 10000
 - If 10 Mhz ref is off by say 2 Hz then frequency may be 20,000 Hz from expected (20 KHz)

Next up – test 24 GHz Wavelab units (repeat same experiment)
- test additional references

Questions?

