

NOTES: Unless Otherwise Specified _____

REVISION BLOCK					
REV	ECO #	ZONE	DESCRIPTION OF CHANGE(S)	DATE	CHANGED/APPROVED

DWG. NO.
 Doc Number
 REV.
 A

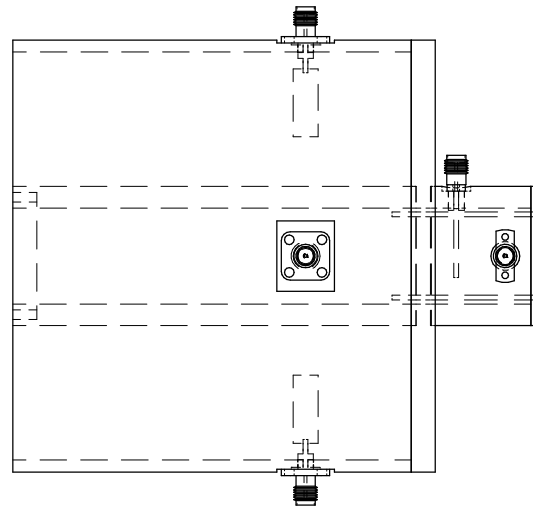
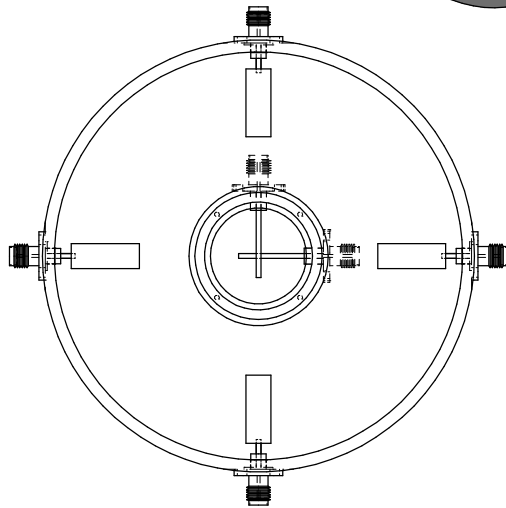
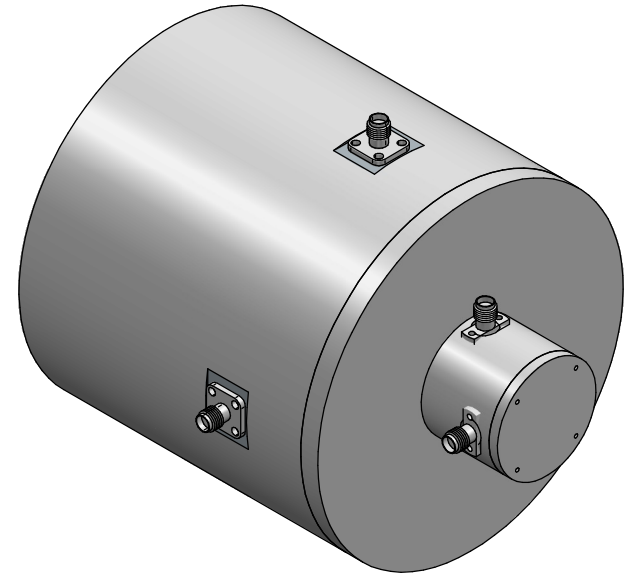
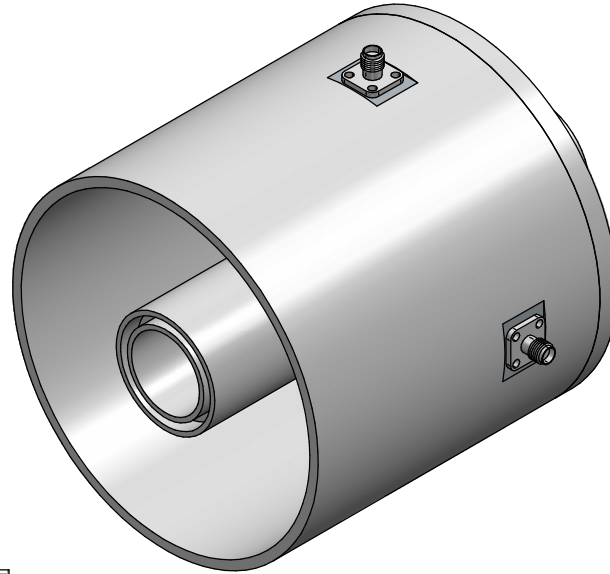

UNLESS NOTED OTHERWISE TOLERANCE BLOCK: DIMENSIONS ARE IN INCHES DECIMALS ANGULAR XX ± .010 ± 0.1 XXX ± .005 XXXX ± .0005 DO NOT SCALE DRAWING MATERIAL: FINISH	PROPRIETARY		TITLE	
	DRAWN BY AFN	DATE	DUAL BAND FEED	
	SCALE NONE	SHEET 1 OF 3		
	FINISH	SIZE A	DRAWING NO.	REV A

NOTES: Unless Otherwise Specified

REVISION BLOCK					
REV	ECO #	ZONE	DESCRIPTION OF CHANGE(S)	DATE	CHANGED/APPROVED

DWG. NO.

Doc Number

REV.
A

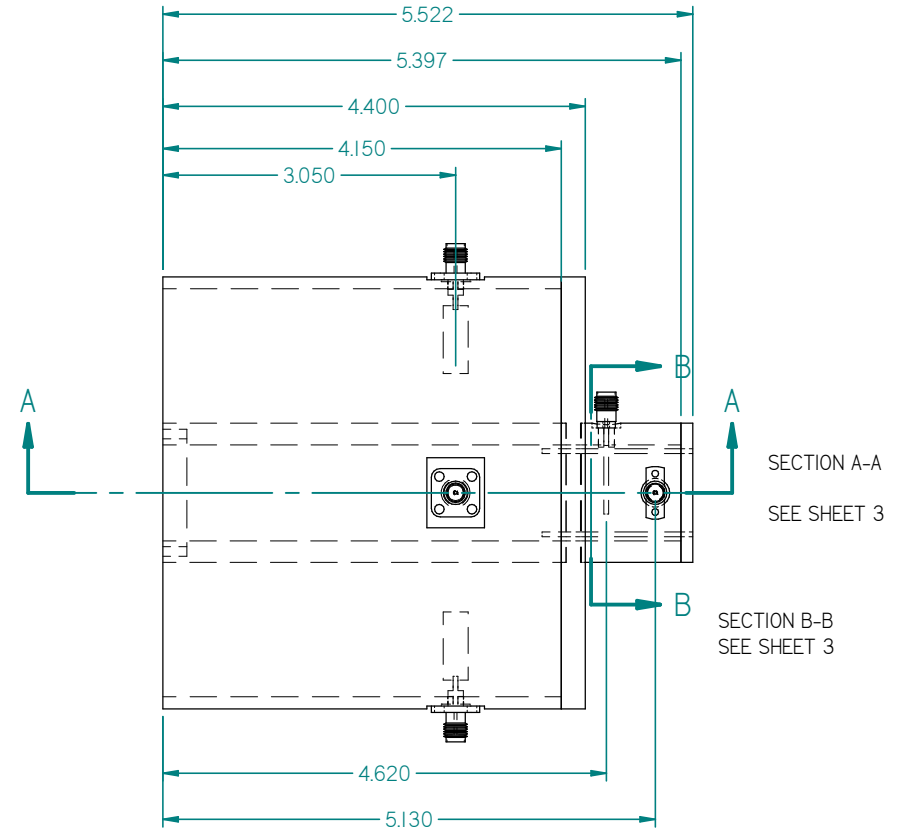
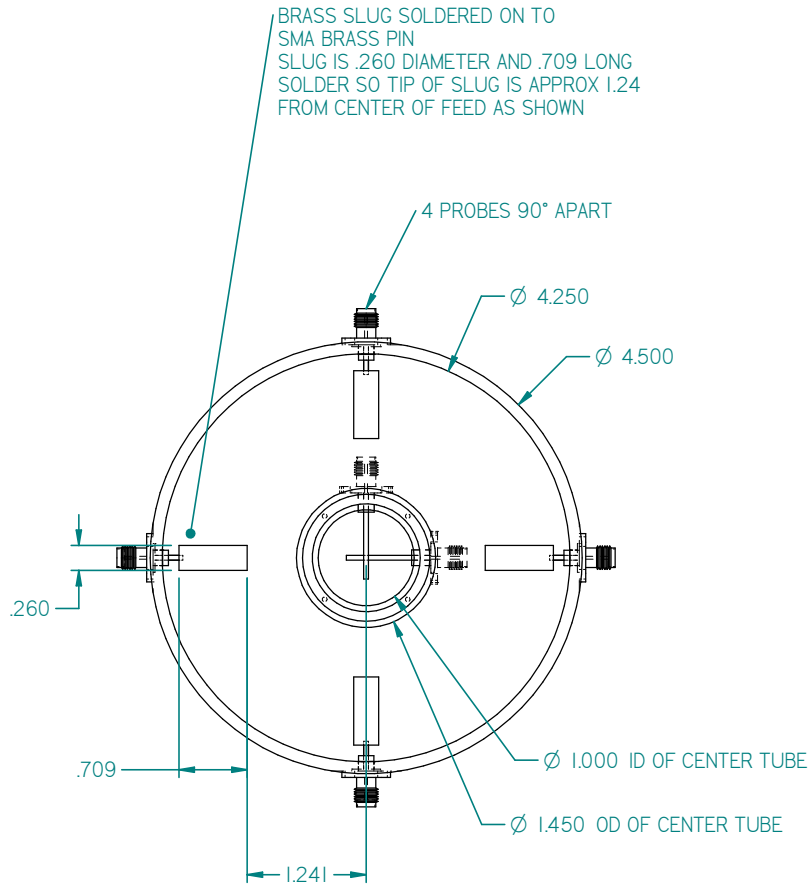

UNLESS NOTED OTHERWISE TOLERANCE BLOCK: DIMENSIONS ARE IN INCHES DECIMALS ANGULAR XX ± .010 ± 0.1 XXX ± .005 XXXX ± .0005 DO NOT SCALE DRAWING MATERIAL:	PROPRIETARY		TITLE <h2 style="text-align: center;">DUAL BAND FEED</h2>	
	DRAWN BY AFN	DATE		
	FINISH	SCALE NONE	DRAWING NO.	
	SHEET 2 OF 3	SIZE A	REV A	

NOTES: Unless Otherwise Specified

REVISION BLOCK					
REV	ECO #	ZONE	DESCRIPTION OF CHANGE(S)	DATE	CHANGED/APPROVED

DWG. NO. Doc Number REV. A

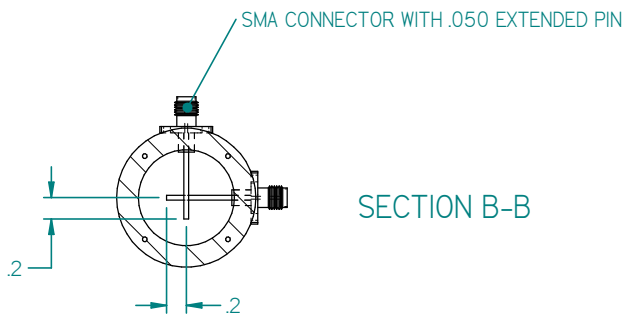
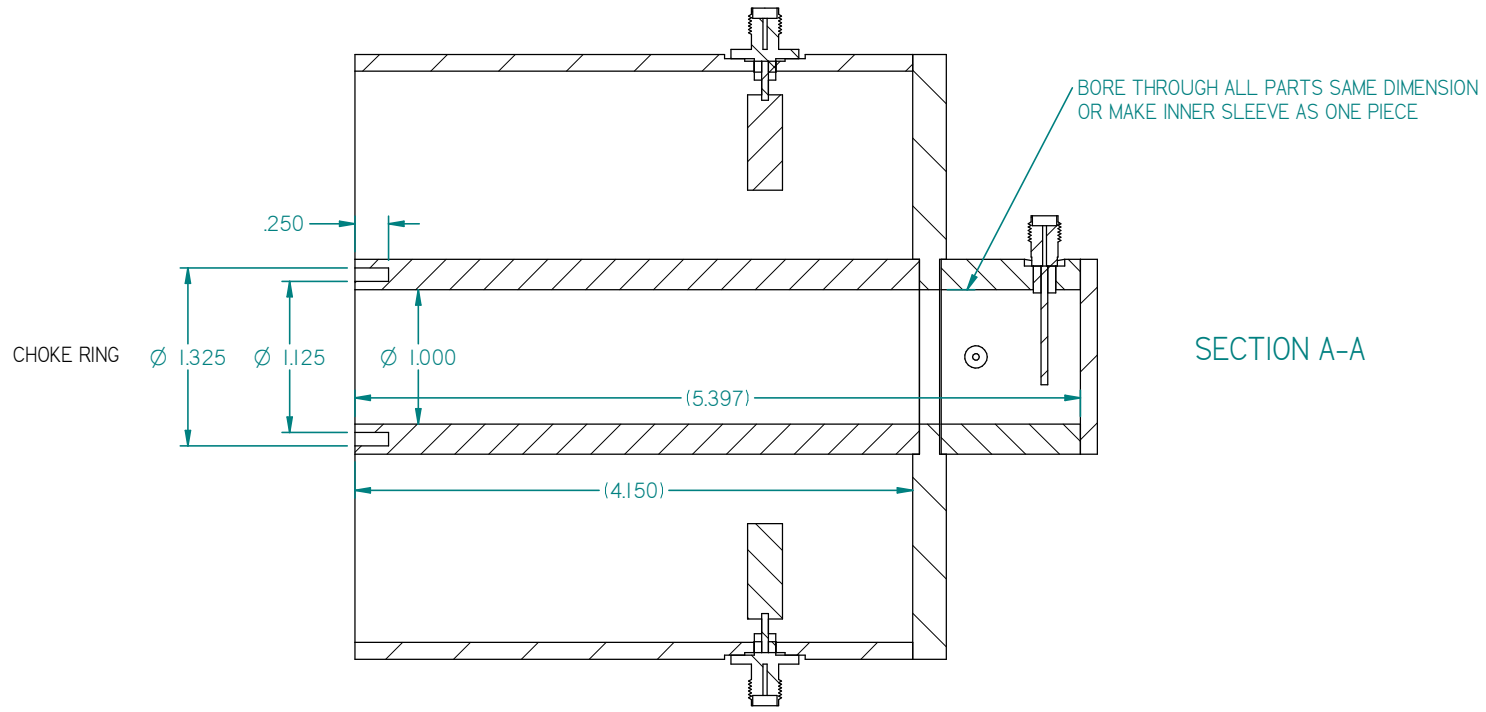

UNLESS NOTED OTHERWISE TOLERANCE BLOCK: DIMENSIONS ARE IN INCHES DECIMALS ANGULAR XX ± .010 ± 0.1 XXX ± .005 XXXX ± .0005 DO NOT SCALE DRAWING MATERIAL: FINISH	PROPRIETARY		TITLE DUAL BAND FEED
	DRAWN BY AFN	DATE	
	SCALE NONE		DRAWING NO.
	SHEET 3 OF 3	SIZE A	REV A