

A 76GHz Transverter

Doing things differently!

By Roger Ray G8CUB

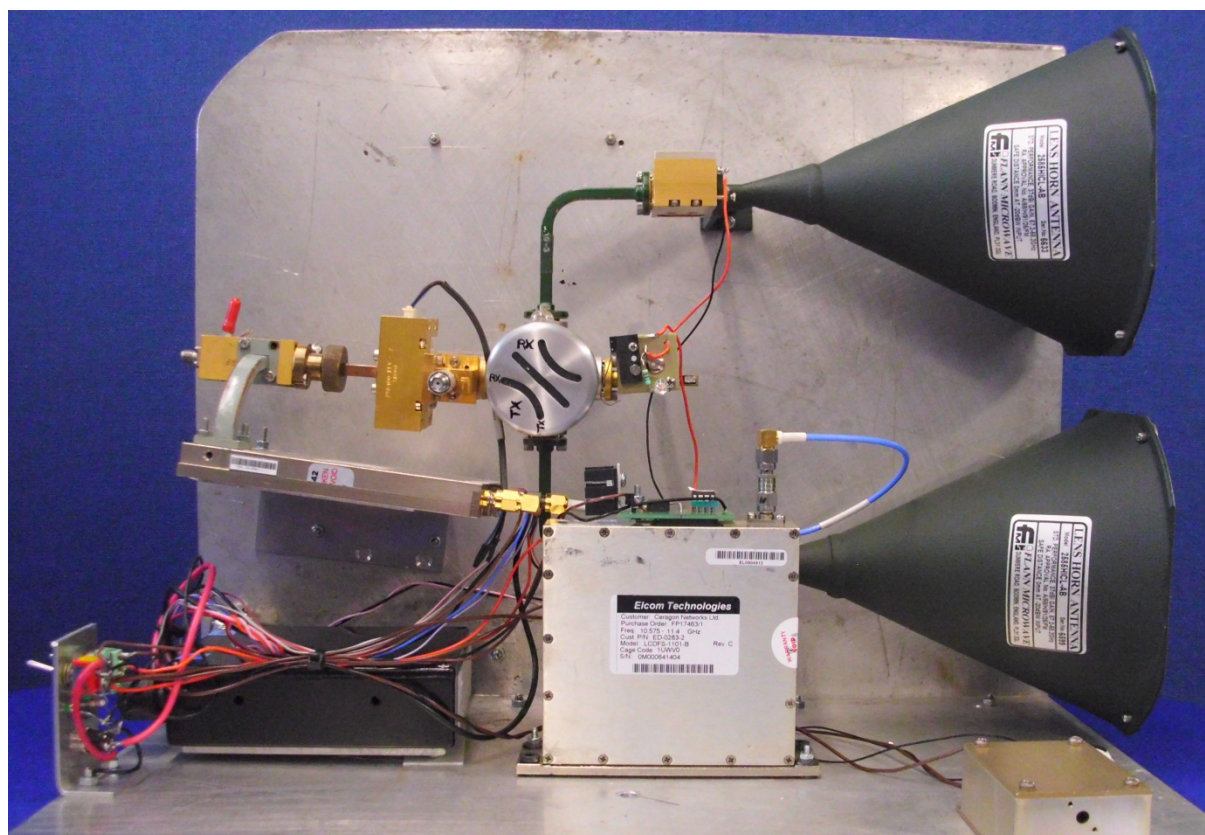

The concept for this 76GHz transverter came about following tests in August 2012. At Ditchling beacon at that time, only John G4EAT could copy signals from Ian G8KQW/P near Ventnor IOW. The difference being that John's transverter was using a fundamental mixer. Chris G0FDZ and myself were using DB6NT type harmonic mixers. These probably had around 16dB NF compared to 8dB or so for the fundamental mixer. John was also using a surplus 58GHz Flann horn, which appeared to work just as well as my 77GHz version.

So to design a new transverter.... Somehow component parts appeared pushing me in direction I eventually took. Harold G3UYM returned my small 10GHz transverter that he had been using. Ebay turned up a pair of 58GHz horns and separately a 60GHz receive system. The later had a plastic dish, a filter, amplifier and harmonic mixer. The amplifier was an Arcom 60N00 which showed around 18dB gain 46 – 70GHz. Not immediately useful, until I hit on the idea of using a 10GHz IF. The advantage of using a high IF is that it would allow image rejection with a length of WR-10 waveguide (cut-off 59GHz).

Looking at what else I had available. I had a Farran fundamental mixer (probably 0-4GHz IF). The Arcom amp and the 2 horns. I also had a WR-15 waveguide switch bought at Martlesham a couple of years ago, and of course the 10GHz transverter. Also I wanted to start with an Elcom synthesiser, as they were proving to be so good.

A quick calculation showed that if I used a 65.6GHz LO, I would have an IF of 10.376GHz. This with the existing transverter would give a final IF of 440-442MHz – not a problem with an FT817 (tx de-limited).

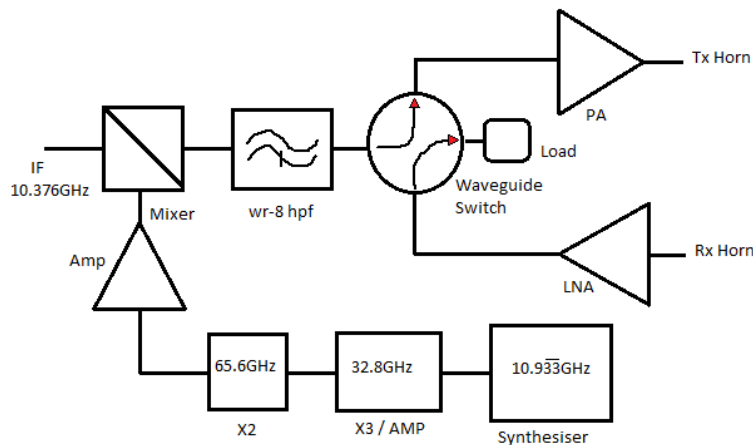

Transverter block diagram. Waveguide switch shown in TX position

Unfortunately the Elcom synths that I had started at 11GHz, and I wanted $65.6/6 = 10.9333333\text{GHz}$. There were however back on Ebay some Elcom units starting at 10.575GHz. A check via Doug VK4OE and the Australian group, responded that the programming was the same as for other Elcom synths – 3.333MHz steps. By a stroke of luck, $65.6/2$ fell within the range of the Broadern module that I had been using on 134Ghz. Just by adding one resistor the acted as a x3 multiplier / amplifier giving up to 0.5W at 32.8GHz! The trick here I had previously found, was to run both positive supplies at 5V and use a DC bias (via the added resistor) to make the mixer work as an attenuator. As long as the input to the LO port is kept below +3dBm, varying the DC voltage on the mixer gives a controllable output.

To get to 65.6GHz I tried a WR-28 mixer used as a doubler. I have found that generally if you drive the RF port of a mixer, they work well as a doubler, extracting the output from the LO port. Sometimes it is necessary to bias or 'tune' the IF port for maximum output. The only mixer I had was a fixed tuned 38GHz unit. A one off effort to move the tuning blocks, produced an output of -4dBm at 65.6GHz. The output was via a piece of WR-15 waveguide. This had to be carefully positioned and angled to get the maximum output. This is the reason that the Broadern module is mounted at the odd angle in the transverter.

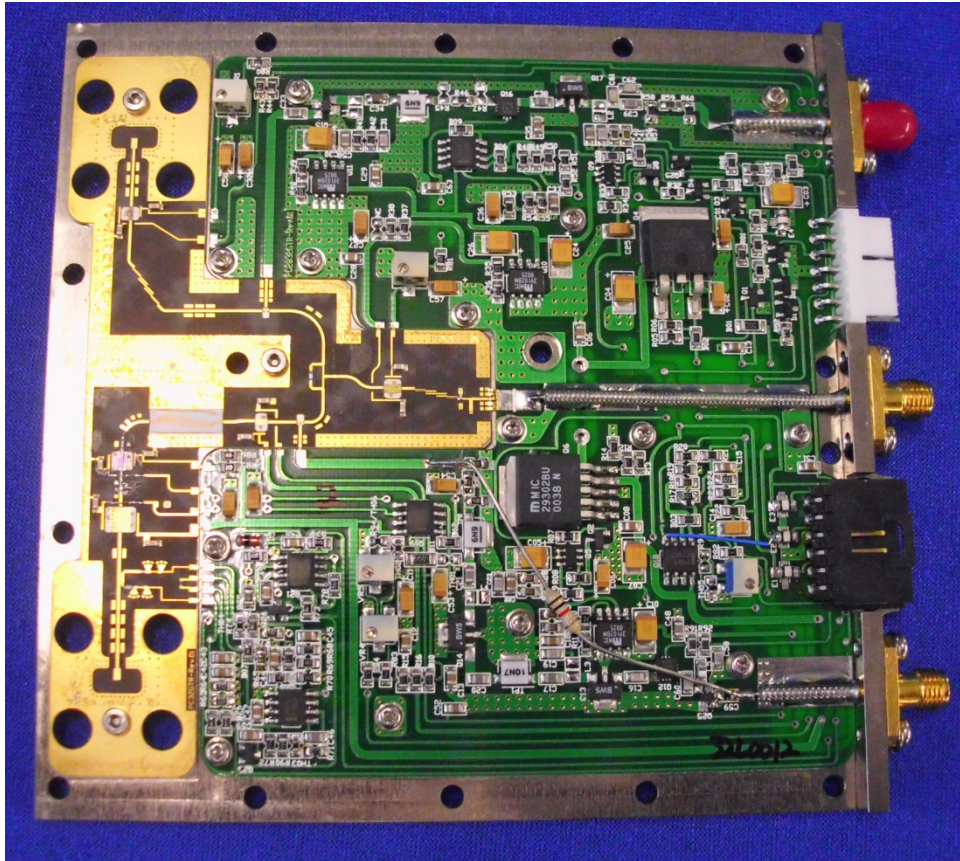

Broadern ED-0296-2 module – resistor added

The output from this mixer used as doubler went via the Arcom amp to the mixer. The amp produced around +11dBm maximum. This was ideal for the fundamental mixer. Input to the mixer was initially a length of WR-10 to reject the image. However when later the PA was added, I found the LO level too high. The solution was to change to WR-8 waveguide (cut-off 73.8GHz). This nicely removed image & LO, to <-60dBC.

Initially the transverter was used like this, going straight through the WG switch to a single horn. On TX 1dB compression occurred at -3dBm output, with a drive of +12dBm at 10GHz.

Just after this the pre-amplifier from Tom WA1MBA arrived, the culmination of a 7 year project, to produce a batch of pre-amps. This had over 30dB gain and a measured noise figure of 5.0dB. I have now made my own noise figure measurement on the complete system, using a borrowed noise source – the average of 3 measurements was 6.1dB. This equates well with Tom's measured noise figure of the pre-amp.

The same week the PA arrived from the States. Claimed output was 100mW with +23dB gain.

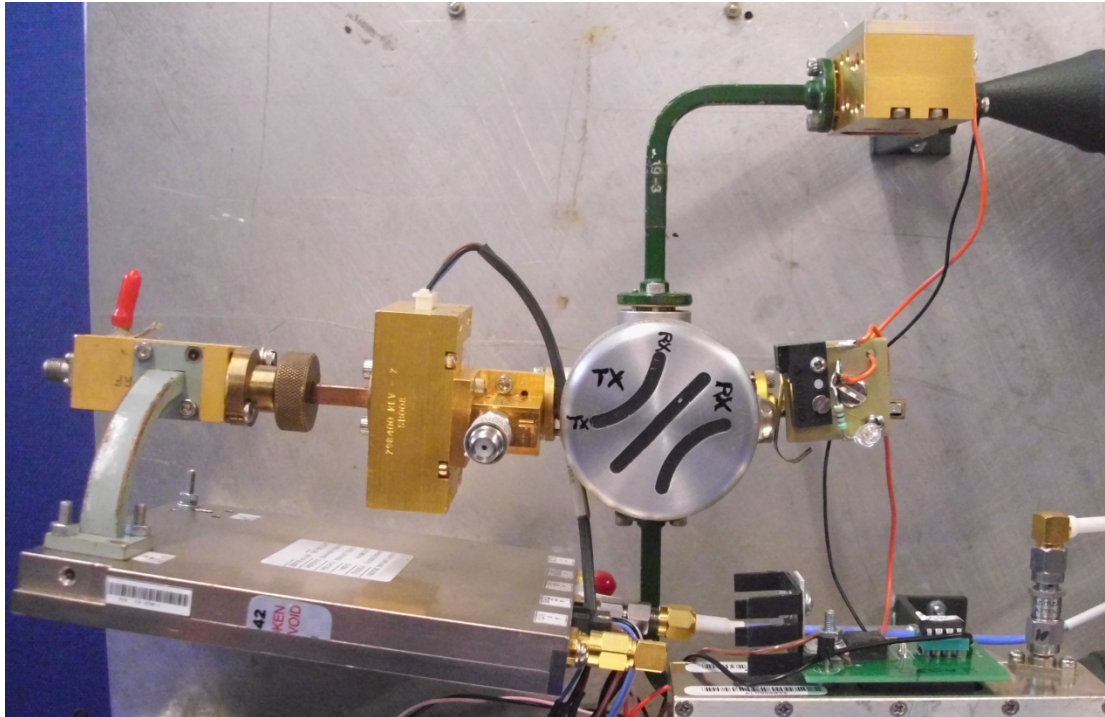

Waveguide switch in TX position

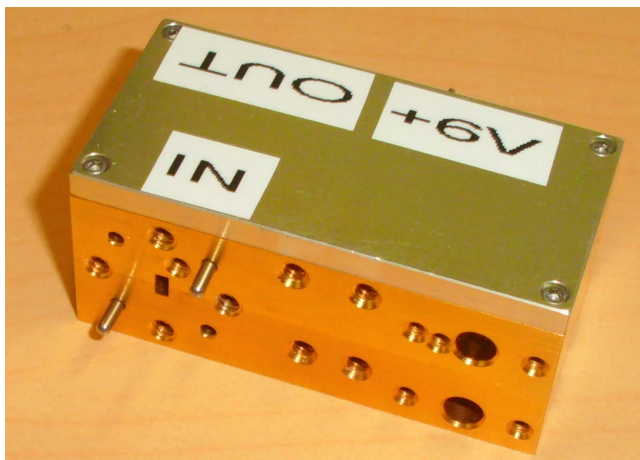

The 100mW PA – single +6V supply

Adding the amplifiers required two waveguide WR-12 bends, that I didn't have. These were eventually located in the States surplus, and duly arrived. What I had forgotten was the orientation of the switch and horns. To get horizontal polarisation, I had to mount the whole assembly vertically, as can be seen in the pictures.

With the 6 position WG switch there was now a problem. Two horns connected via over 50dB of amplification at 76GHz, in an intermediate switch position! To overcome this I added a plastic 'foot' to the switch knob. Only allowing the TX amp to be on when the switch was in the right position.

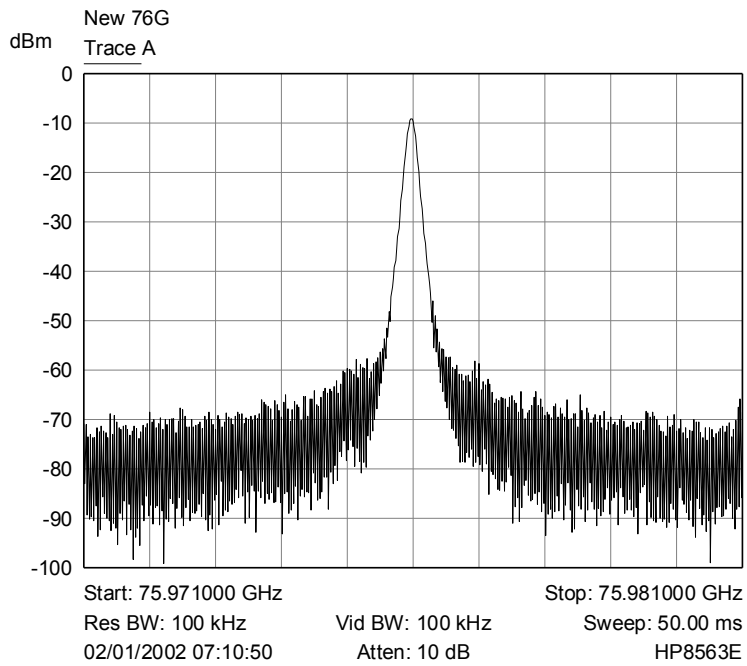

Tx output of +19dBm

Performance of the transverter has been excellent. Reports were 59/59 FM with G8ACE, and 59 / 599 SSB/CW with G8KQW from Firlie beacon over a 94km path.



In Operation at Firlie beacon with 10GHz transverter and FT817 fitted.

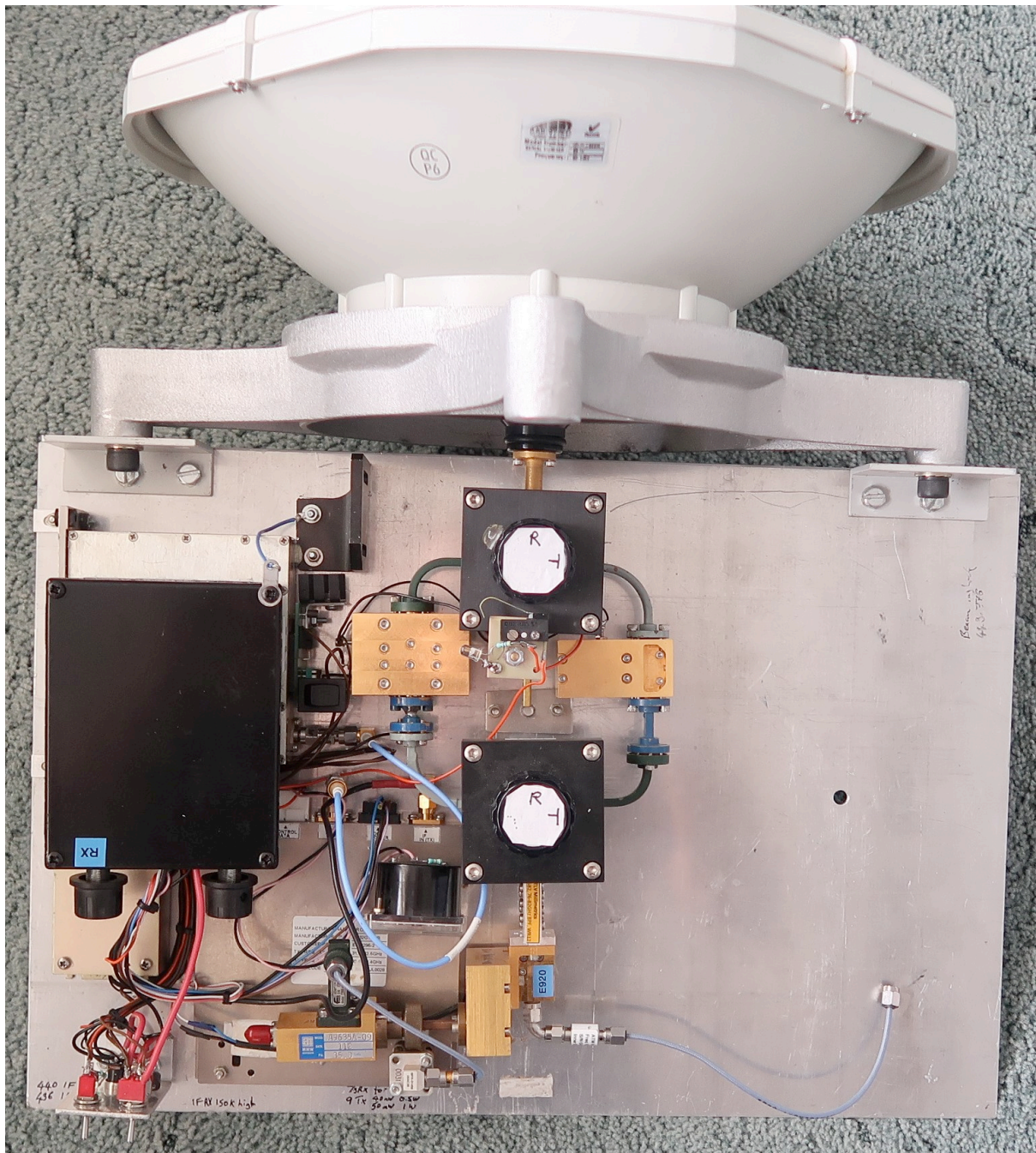

How the transverter looks in 2019, with 30cm dish, and two WG switches. The space on the right is for the 10GHz (IF) Transverter.