

# Motorizing WR-10 & WR-15 Waveguide Switches

Al Ward W5LUA

## Introduction

I acquired WR-10 and WR-15 manually operated waveguide relays and I wanted to automate their operation. The primary reason was to insure that my transverter was properly sequenced on transmit so as not to damage the LNA or the PA. I also wanted a quick way to automatically switch between cold sky and a termination. This sort of measurement is useful when making sky temperature measurements with respect to 290K.

## Millimeter Wave Relay Characteristics

These millimeter wave type waveguide relays are a slightly different design than the customary 4 port designs used on the lower microwave bands. The lower frequency 4 port designs rotate 90 degrees to change states. These millimeter wave relays obtain a different position every 45 degrees of knob rotation. Besides the normal 90 degree bend in the relay, there is a straight through port that was once used for a "loop back test" that allowed the transmitter to be injected directly into the receiver for a "built in test function". The configurations we will most likely use are shown in Figures 1 and 2. Figure 1 shows a straight through path between the receiver and the antenna. Figure 2 shows a 90 degree path from the transmitter to the antenna and a 90 degree path from the receiver to a port that is terminated in a load.

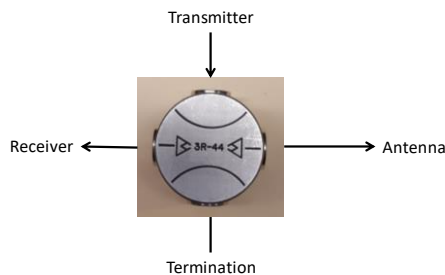

Figure 1 Waveguide Relay in Receive Position

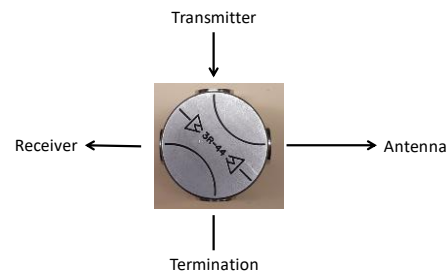

Figure 2 Waveguide Relay in Transmit Position

## Motorizing the Manual Waveguide Switch.

Based on the desired configurations shown above, the waveguide relay shaft needs only to be moved 45 degrees between receive and transmit states. I acquired a small reversible 12vdc motor that travels at about 15 rpm. Limit switches will be used to stop and reverse the motion of the motor. After removing the knob from the waveguide switch, I inserted a long #4-40

screw through the shaft. Depending on your style of waveguide relay, you may or may not have to drill a hole to thread the #4-40 screw into. The #4-40 screw acts as a lever to actuate the micro-switches.

The micro-switches are mounted on an aluminum plate which is attached to the waveguide relay. The switches are oriented such that when the switches are fully compressed with the lever, the waveguide relay is either in the receive mode shown in Figure 3 or the transmit mode as shown in Figure 4.

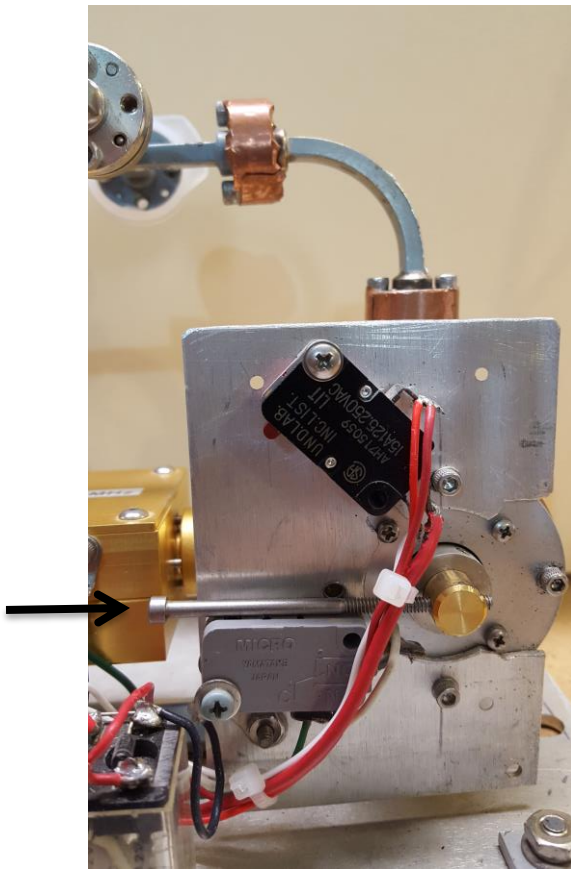

Figure 3 Waveguide Relay in the Receive position

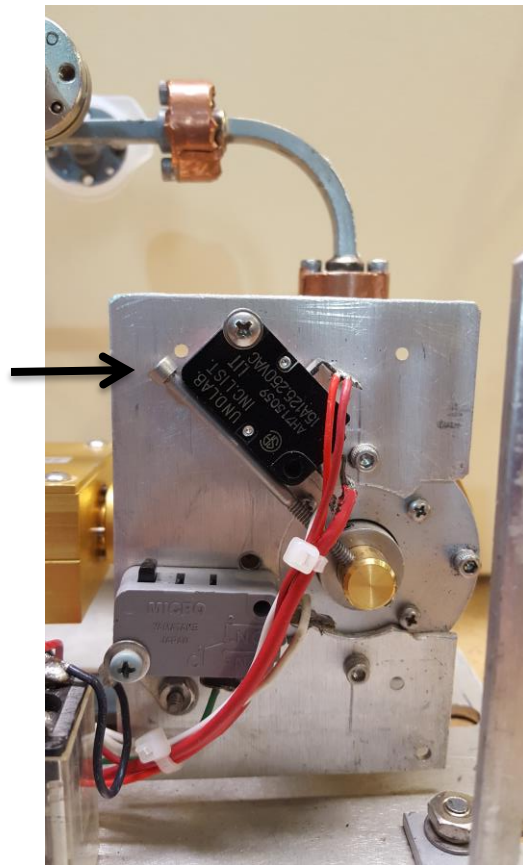

Figure 4 Waveguide Relay in the Transmit position

The switches and motor are wired as shown in Figure 5. Switch S1 is the upper switch and switch S2 is the lower switch as shown in Figures 3 and 4. The normal “resting” state is in the receive mode where S2 which is a normally closed switch is held open to leave the motor unenergized. On transmit +12V from the sequencer board is applied to the “+12V in to XMIT” port. This energizes RY1 and the motor causing the motor to rotate towards the transmit position. Once the motor has moved the waveguide relay to the transmit position, the lever compresses S1 causing the motor shut to shut off, even though RY1 is still energized. Only after the waveguide relay is fully in the transmit position, is the voltage “12V out on XMIT” available. I use this voltage to control another 12v relay that has a NO contact that pulls the PTT line of

the transverter to ground. The transverter is guaranteed not to go to transmit unless the waveguide relay is fully in the transmit state.

When the sequencer board removes voltage from the “+12V in to XMIT” port, then relay RY1 is de-energized and the motor moves the waveguide relay toward the receive position and when the lever hits S2 again the motor shuts off and the waveguide relay is back in the receive position.

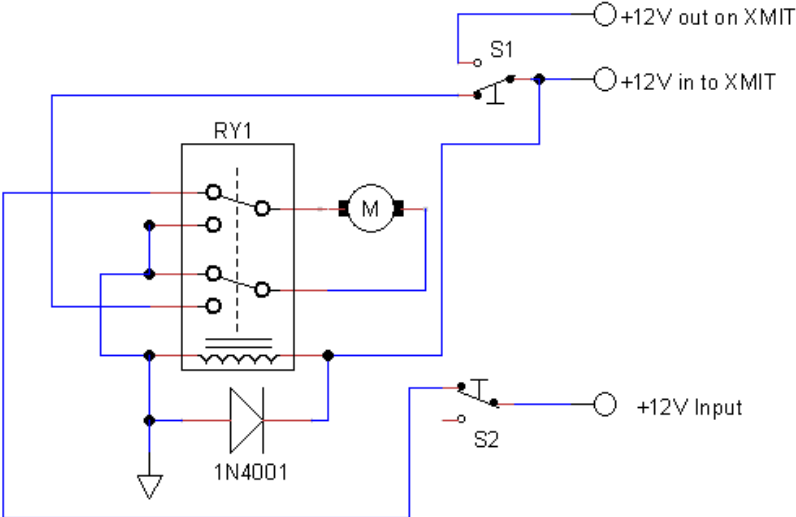

Figure 5 Schematic diagram of relay switching circuit

Figure 6 shows a top view of the completed motorized waveguide switch including the motor and shaft coupling.



Figure 6 Motorized waveguide relay

**Summary**

A simple approach to motorizing a millimeter wave switch has been described. The circuit also provides a safety interlock to make sure the transverter or PA will not go to transmit if the waveguide relay is not fully engaged in the transmit position.

73

Al Ward

W5LUA

August 28, 2019